

SINCE 1944

* Specifications in this catalog are subject to change without prior notice.
* Please contact us or visit our site for more product information.

DL S series (10"~21")

Powerful CNC Turning Center (En)

DL 25(M), DL 30(M), DL 40(M), DL 45(M), DL 55(M)
DL 30L(M), DL 40L(M), DL 45L(M), DL 55L(M)

www.ffg-dmc.com



FFG DMC CO.,LTD.

631-821,86,Sandan 2-gil, Jinbuk-myeon, Masanhappo-gu,
Changwon-si, Gyeongsangnam-do, Korea

Phone : +82-(0)55-340-8200

Fax : +82-(0)55-340-8394

E-mail : sales@dmcmt.com

www.ffg-dmc.com



©FFG DMC 2017.11.09



DL S series

(10"~21")

DL 25(M), DL 30(M), DL 40(M), DL 45(M), DL 55(M)
DL 30L(M), DL 40L(M), DL 45L(M), DL 55L(M)

DL S series is designed to offer best features of heavy duty cutting, sufficiently large work space, heat distortion prevention system, highly-efficient machining to satisfy customer needs.

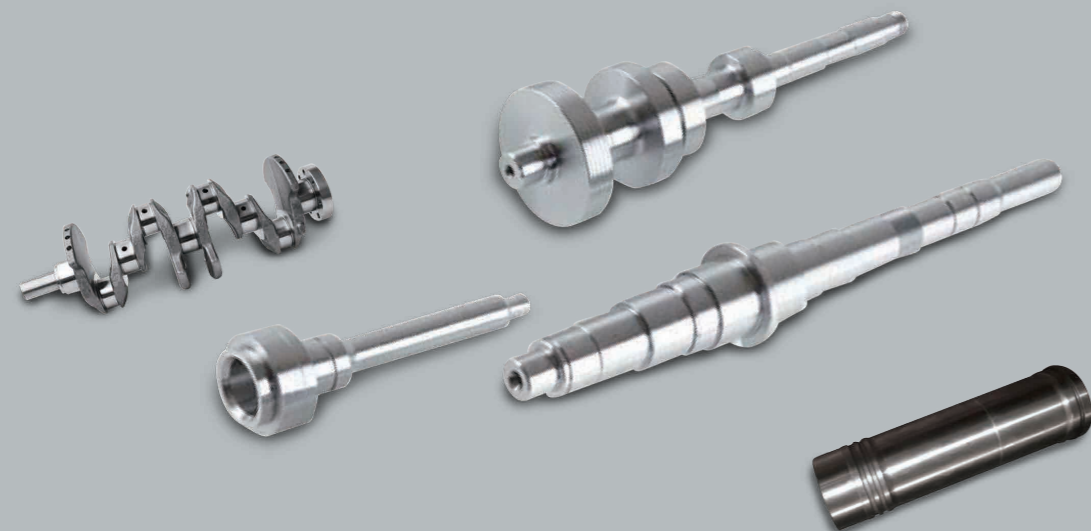

DL 25

Travel (X/Z) (mm)(inch)	230 × 1,130	9.06 × 44.49
Guideway Type	BOX Way	
Spindle speed (rpm)	3,500	
Number of tools (pcs)	12	



DL 40

Travel (X/Z) (mm)(inch)	305 × 1,305	12.01 × 51.38
Guideway Type	BOX Way	
Spindle speed (rpm)	2,500	
Number of tools (pcs)	10	



DL 45

Travel (X/Z) (mm)(inch)	350 × 1,530	13.78 × 60.24
Guideway Type	BOX Way	
Spindle speed (rpm)	2,000	
Number of tools (pcs)	12	



DL 55

Travel (X/Z) (mm)(inch)	350 × 1,530	13.78 × 60.24
Guideway Type	BOX Way	
Spindle speed (rpm)	1,700	
Number of tools (pcs)	12	

High Productivity

Spindle



Heat radiating fan type headstock with minimum heat distortion

Heat radiation fan typed Rib structure minimizes headstock distortion by heat generation and prevents change of accuracy according to temperature increase.

In addition, balanced heat generation design of headstock also minimizing heat effect.

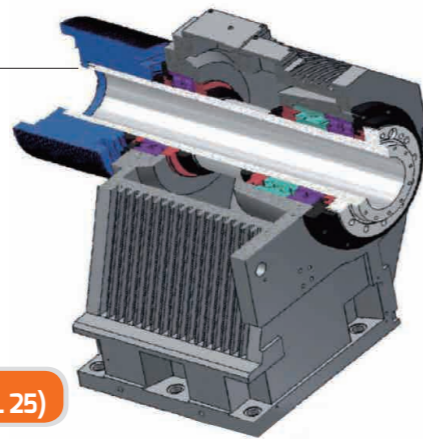

Maximum spindle speed **3,500rpm (DL 25)**

Maximum spindle motor power **30/37kw (40/50hp) (DL 55)**

() : option

		DL 25	DL 30	DL 40	DL 45	DL 55
Chuck size	inch	10(12)	12	15(18)	18(21)	21
Spindle Bore diameter	mm/inch	86/3.39	105/4.13	132(161)/5.2(6.34)	132(161)/5.2(6.34)	181/7.13
Max. Spindle Speed	rpm	3,500	3,000	2,500	2,000	1,700
Main Spindle Motor	kw/hp	18.5/25	18.5/25	22/30	37/50	37/50
Max. Spindle Torque	kgf·m/lbs·ft	39.7/287	47.9/346	96.3/697	300.4/2,173	300.4/2,173
Spindle Driven Method	-	Belt	Belt	Belt	Belt	Belt
Spindle Nose	-	A2-8	A2-8	A2-11	A2-11	A2-15

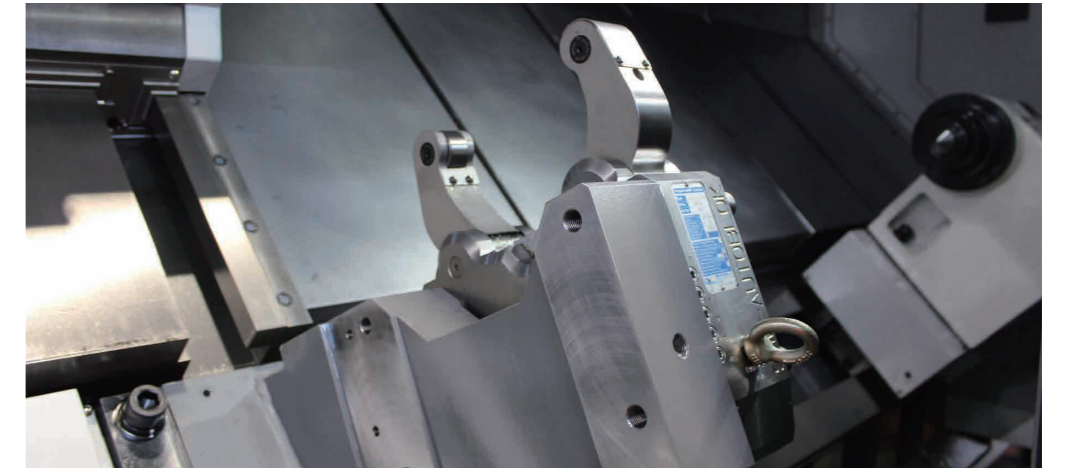

DL 25

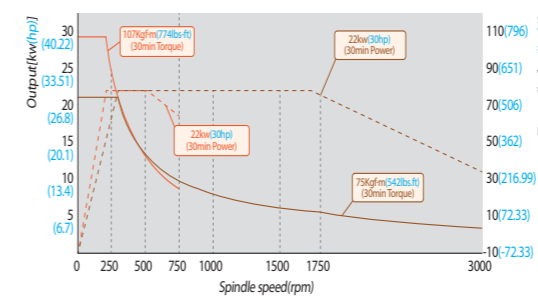

DL 30

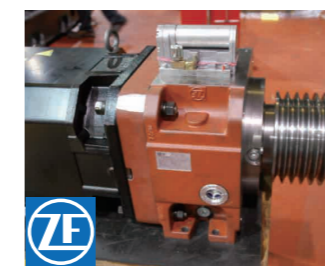
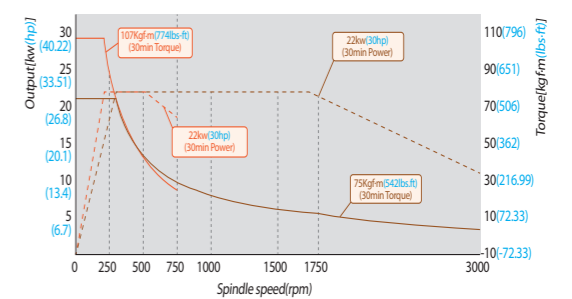

German technology ZF Gear Box

To provide heavy duty machining. High output converting gearbox equipped as standard feature.

DL 25 / DL 30 / DL 40 : OPT., DL 45 / DL 55 : STD.

DL 40

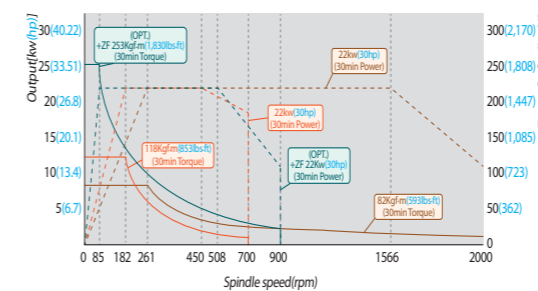

DL 45 / DL 55

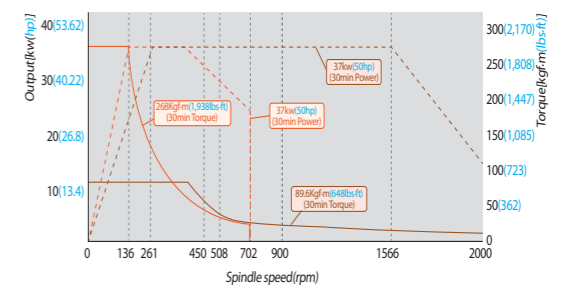

High Productivity

Bed



45° Slant Bed prevents vibration or unwanted strain

- High torque and heavily ribbed 45° bed is great for rotational rigidity and bending rigidity. Slanted bed offers good work piece accessibility and chip removal.
- Wide guide way and 6-faces contact slide way were processed with high frequency heat and meticulous machining for long-lasting high precision and strong cutting. Hand scrapping on the cast iron (other competitors use turcite)

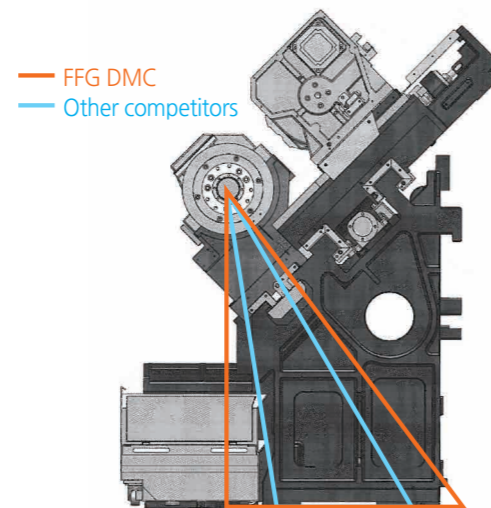
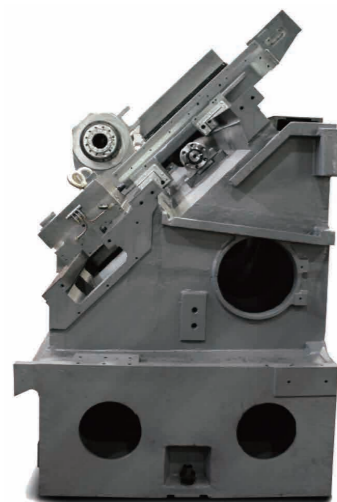

Highest precision even in intermittent cutting with great absorption ability

- 45 degree slant bed is great for vibration-dampening capability. High precision quality is guaranteed in a heavy duty cutting and enhanced machine life with elimination of distortion or deformation.

Offers Wide Bed Leveling

- Spindle overhang prevention (provides greater stability)
- **FFG DMC** : Right triangle
- **Other company** : Obtuse triangle
- Guaranteed stability against cutting resistance.
- Reduced vibration during high-speed rotation.
- Strong structure against any deformation in long-term.
- Protruding bed leveling boss ensures greater stability in performance.

Turret

DL 25/30(L)/40(L)/45(L)/55(L) High Torque Servo Turret



	DL 25/30(L)/40(L)	DL 45(L)/55(L)
Tool Size	□25, Ø50 (□0.98", Ø1.97")	□32, Ø60 (□1.26", Ø2.36")

- The 12-position turret enables various combinations of O.D./I.D. tool holders in all positions, FANUC servo motor index and 3-pieces curvic coupling of 4,520kgf hydraulic clamping power guarantees speediness in tool change, quiet and stable machining experience, and versatile cutting abilities such as heavy duty and intermittent cutting.
- Turret indexing is non-stop bi-direction with a 0.2 sec next station time each turret stations capable of accepting both milling and turning tools.

DL 25M/30(L)M/40(L)M/5(L)M/55(L)M High Torque BMT Servo Turret

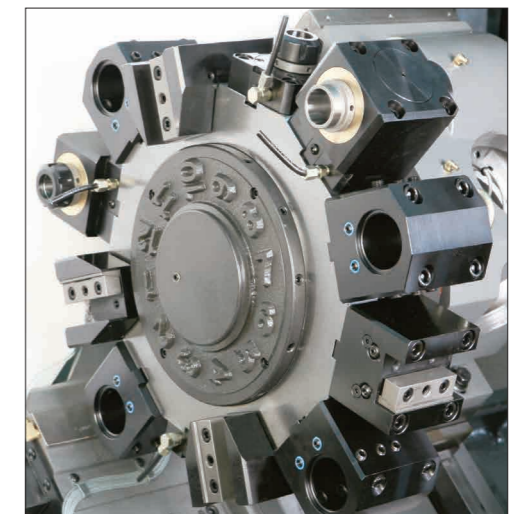

	DL 25M/30(L)M/40(L)M	DL 45(L)M/55(L)M
Tool Holder	BMT 65	BMT 75

- The 12 station BMT turret with the curvic coupling and hydraulic clamping power
- The 12-station turret of curvic coupling and hydraulic clamping capability effectively prevents vibration in heavy cutting. Longer tool life and high accuracy indexing add to great precision machining. All turret acceleration/deceleration clamp activities are controlled by the high torque servo motor. The milling tool holder (BMT65, BMT75), which is to be attached on the turret face, is operated by the separate servo motor, and superb accuracy and precision are greatly improved with the key type.

Standard Turret

- 3piece curvic coupling applied : Prevent overhang while rotating
- Turret Index position : 12position Flexible

	Turret Index method	Max. No. of tools	Turret Index Time(one face)
DL 25/DL 30(L)	Servo	12	0.2
DL 25M/DL 30(L)M	Servo	12 / BMT 65	0.2
DL 40(L)	Servo	10	0.2
DL 40(L)M	Servo	12 / BMT 65	0.18
DL 45(L)/DL 55(L)	Servo	12	0.25
DL 45(L)M/DL 55(L)M	Servo	12 / BMT 75	0.25

Mill Turret (DL 45 / DL 55)

- Tool size : □32(1.26"), Ø60(2.36")
- Turret clamping force : 11,220 kgf(24,735, 87,165lbs)

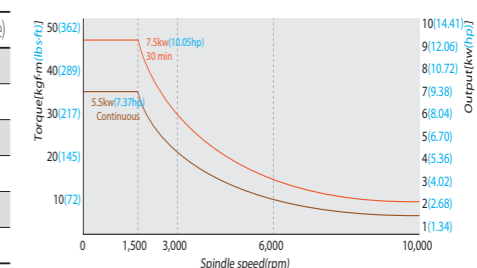

High Productivity

X/Z Axis

	Axis travel(X/Z)[mm(inch)]	Rapid travel(X/Z)[m/min(ipm)]
DL 25	230/1,130(9.06/44)	20/24(787.40/944.88)
DL 30	230/1,130(9.06/44)	20/24(787.40/944.88)
DL 30L	230/2,130(9.06/84)	20/18(787.40/708.66)
DL 40	305/1,305(12.01/51.38)	18/20(708.66/787.40)
DL 40L	305/1,705(12.01/67)	18/20(708.66/787.40)
DL 45	350/1,530(13.78/60.24)	20/18(787.40/708.66)
DL 45L	350/2,330(13.78/91.73)	20/18(787.40/708.66)
DL 55	350/1,530(13.78/60.24)	20/18(787.40/708.66)
DL 55L	350/2,330(13.78/91.73)	20/18(787.40/708.66)

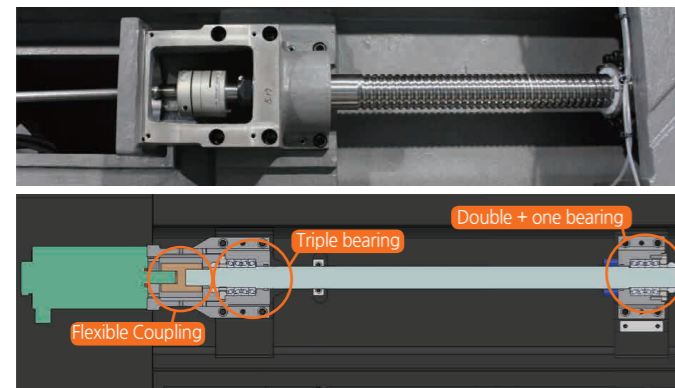

Double Anchoring Ball Screw Supporting structure

- Optimal combination of triple angular ball bearing, double angular ball bearing, and radial bearing for the highest rigidity and strength in thrust or radial direction moving.
- Minimized heat distortion with pretension process
- Flexible coupling connects ball screw and servo motor for intact power supply without lost motion and vibration damping ability.
- Ball Screw - DL25,DL30 X/Z: $\phi 32/50(1.26"/1.97")$, DL40 X/Z: $\phi 36/50(1.42"/1.97")$, DL45,DL55 X/Z: $\phi 40/50(1.57"/1.97")$

Hydraulic Steady Rest Option

- The hydraulic steady rest provides stable and accurate machining of long workpiece.



Model	Specifications
DL 25 / 30	$\phi 13 \sim \phi 152(\phi 0.51 \text{ inch} \sim \phi 5.98 \text{ inch})$
	$\phi 20 \sim \phi 165(\phi 0.79 \text{ inch} \sim \phi 6.50 \text{ inch})$
DL 40	$\phi 13 \sim \phi 152(\phi 0.51 \text{ inch} \sim \phi 5.98 \text{ inch})$
	$\phi 20 \sim \phi 165(\phi 0.79 \text{ inch} \sim \phi 6.50 \text{ inch})$
DL 45 / 55	$\phi 35 \sim \phi 245(\phi 1.38 \text{ inch} \sim \phi 9.65 \text{ inch})$
	$\phi 20 \sim \phi 165(\phi 0.79 \text{ inch} \sim \phi 6.50 \text{ inch})$

Wide saddle

Wide and Unique 6 faces arresting type box-way with high frequency heat treated and precision grounded slide ways to ensure machine life-time and high accuracy

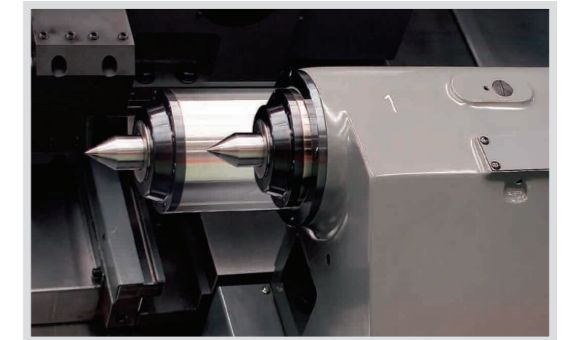
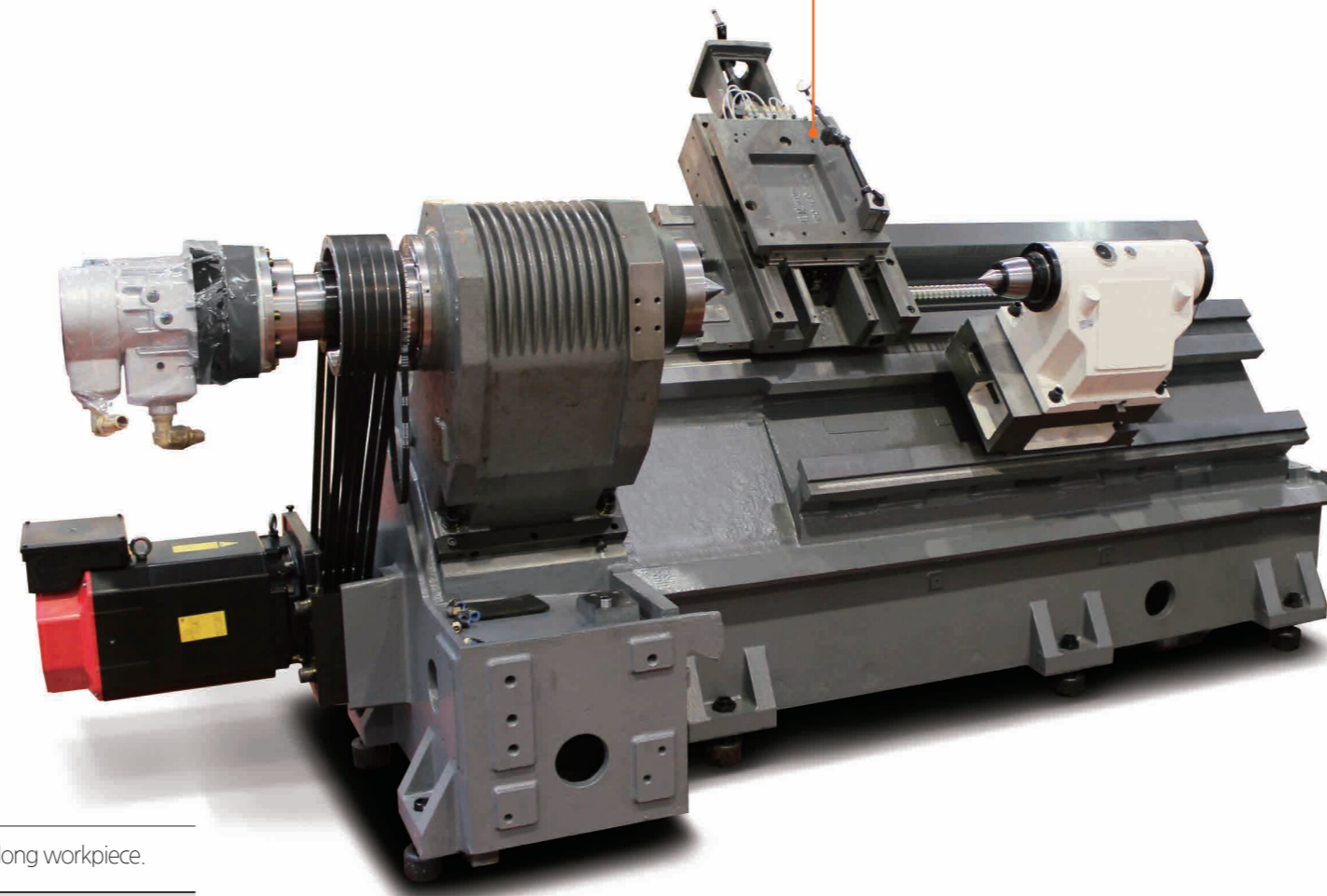
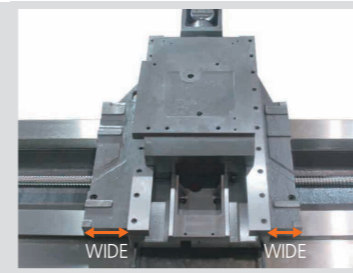

Tailstock

- The largest in its class, this ultra-strength tailstock offers long-lasting lifetime with a built-in live center. Tailsleeve can be easily controlled with a foot switch or M-codes.
- Programmable tailstock
The tailstock and sleeve are operated by M-code automatically.

	Unit	DL 25 / DL 30
Tailstock Quill diameter	mm(inch)	110(4.33)
Tailstock Quill stroke	mm(inch)	100(3.94)
Max. Thrust of Tailstock Quill	kgf(lbs)	1,008(2,222)
Max. Hydraulic pressure	kgf/cm ² (psi)	40(568.94)
Tailstock Quill taper	-	MT#5

	Unit	DL 40
Tailstock Quill diameter	mm(inch)	130(5.12)
Tailstock Quill stroke	mm(inch)	120(4.72)
Max. Thrust of Tailstock Quill	kgf(lbs)	5,275(11,629)
Max. Hydraulic pressure	kgf/cm ² (psi)	40(568.94)
Tailstock Quill taper	-	MT#4

	Unit	DL 45 / DL 55
Tailstock Quill diameter	mm(inch)	160(6.30)
Tailstock Quill stroke	mm(inch)	150(5.91)
Max. Thrust of Tailstock Quill	kgf(lbs)	8,160(17,989)
Max. Hydraulic pressure	kgf/cm ² (psi)	40(568.94)
Tailstock Quill taper	-	MT#5

Accuracy

X/Z Axis

- \ Stable Bed Structure
- \ Wide Rigid Angular Box Slide Way Structure
- \ Optimized model for strong cutting

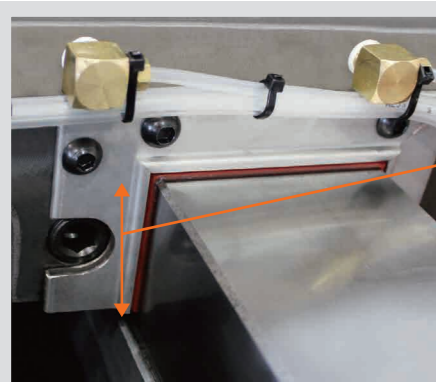
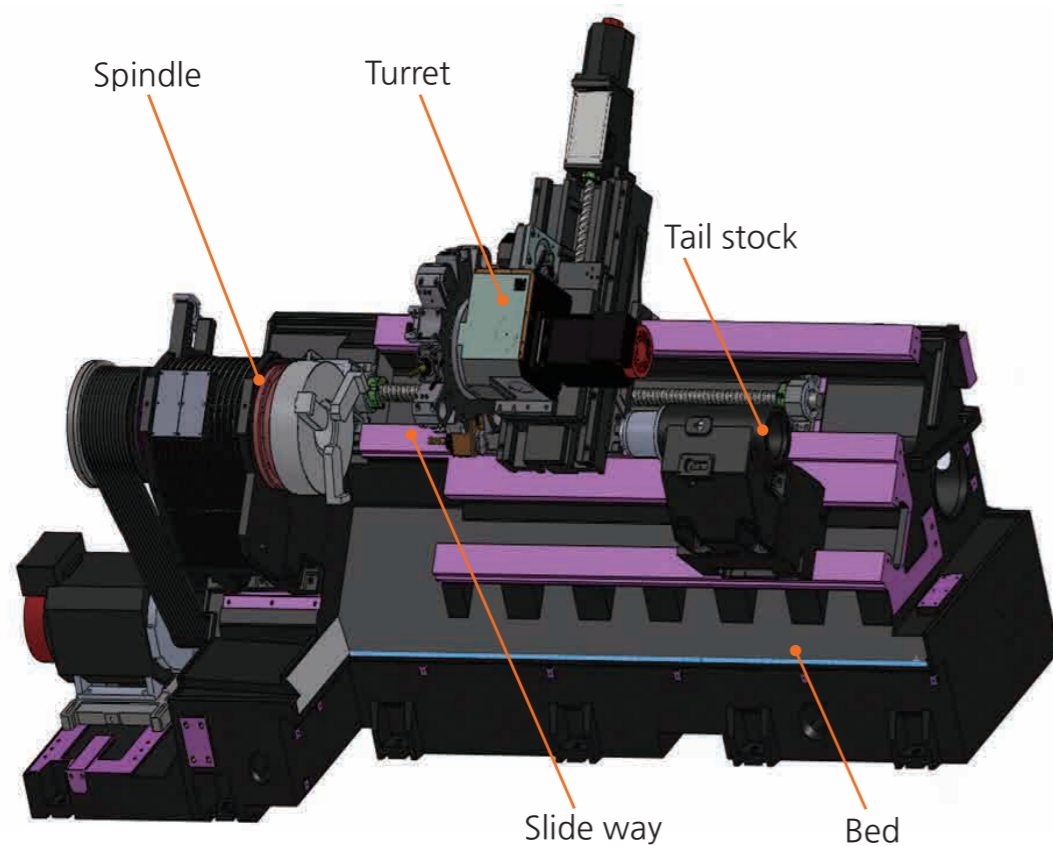

Box way

1.8x thicker than other competitors

- o X,Z axis
- Wide inner 6-faces Slide way, after high frequency Heat Treatment, can be precision grinded so that keep high precision, strong cutting long-time. Hand scrapping on cast iron. (previous model)

Surface Roughness

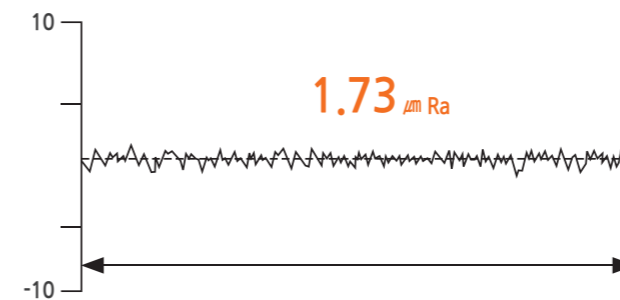

DL 30	
Tool	Diamond tool <nose radius 0.020 inch>
Material	AL 150 <Aluminum>
Cutting speed	227.3m/min(8,948.82ipm)
Feedrate	0.05mm/rev(0.002ipr)
Depth of cut	0.1mm(0.0039inch)
Out diameter	201mm(7.91inch)

Roundness

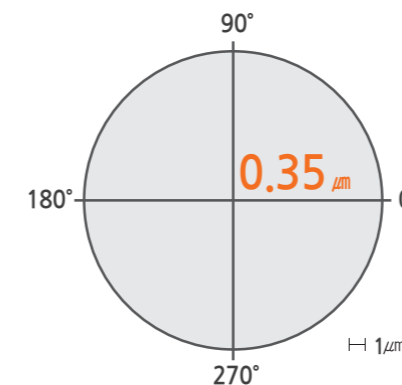

DL 30	
Tool	Diamond tool <nose radius 0.020inch>
Material	AL 150 <Aluminum>
Cutting speed	227.3m/min(8,948.82ipm)
Feedrate	0.05mm/rev(0.002ipr)
Depth of cut	0.1mm(0.0039inch)
Out diameter	201mm(7.91inch)

Example Of Machining

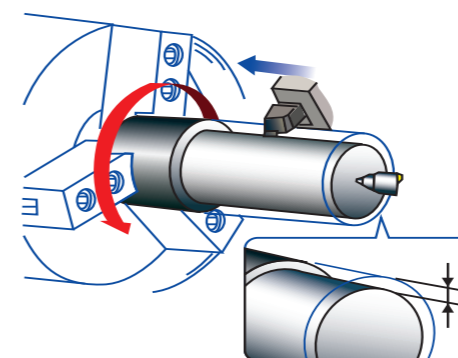

o This is actual cutting result. It might be not available under certain circumstances.

	DL 30	DL 40
Tool	25mm x 25mm (0.98inch x 0.98inch)	32mm x 32mm (1.26inch x 1.26inch)
Spindle speed	890 rpm	367 rpm
Cutting speed	140mm/min (5.51ipm)	150mm/min (5.91ipm)
Depth of cut	8mm(0.31inch) (Spindle Load 50%)	10mm(0.39inch) (Spindle Load 65%)
Feedrate	0.3mm/rev (0.012ipr)	0.4mm/rev (0.016ipr)

User-Friendly, Safe and Designed for Operator Efficiency / Ergonomics

2-Panel Safety Glass

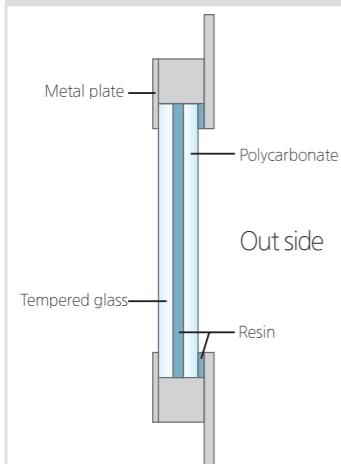

LED Working Light



+ Long-life LED lighting creates well lighted work environments.

Chuck open/close identification

+ Chuck status is regularly checked for smooth operation

X-Link Slide Cover

+ Applied X-Link Slide Cover, minimized trouble and long-lasting life

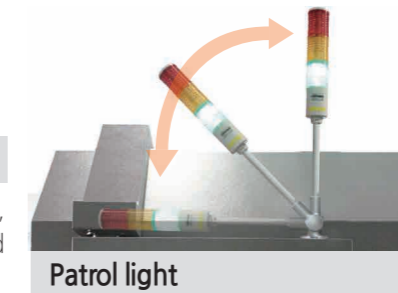

Patrol light

+ LED 3 color wrapped folded when shipping

Front Door Interlock Device



+ CE standard safety switch can sense door open and close; door is closed during operation

Spindle Load Meter Gauge

RS232C (Input/output interface)



+ USB port

Oil retrieval box



Oil leak prevention

+ Cover to ensure the pleasant work place.
+ Long-lasting life with wiper protection.



3 steps filter coolant tank Easy Clean-up & Prevent Coolant over flow

+ Chip conveyor installation - front/side type

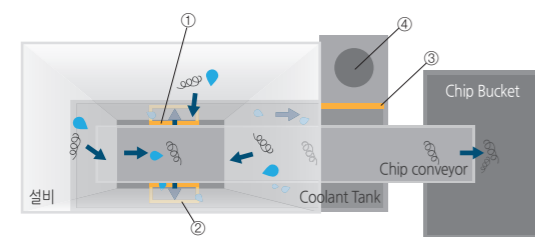

- ① 1st step : Mesh filter
- ② 2nd step : Bucket mesh
- ③ 3rd step : Mesh filter
- ④ 4th step : Motor suction filter

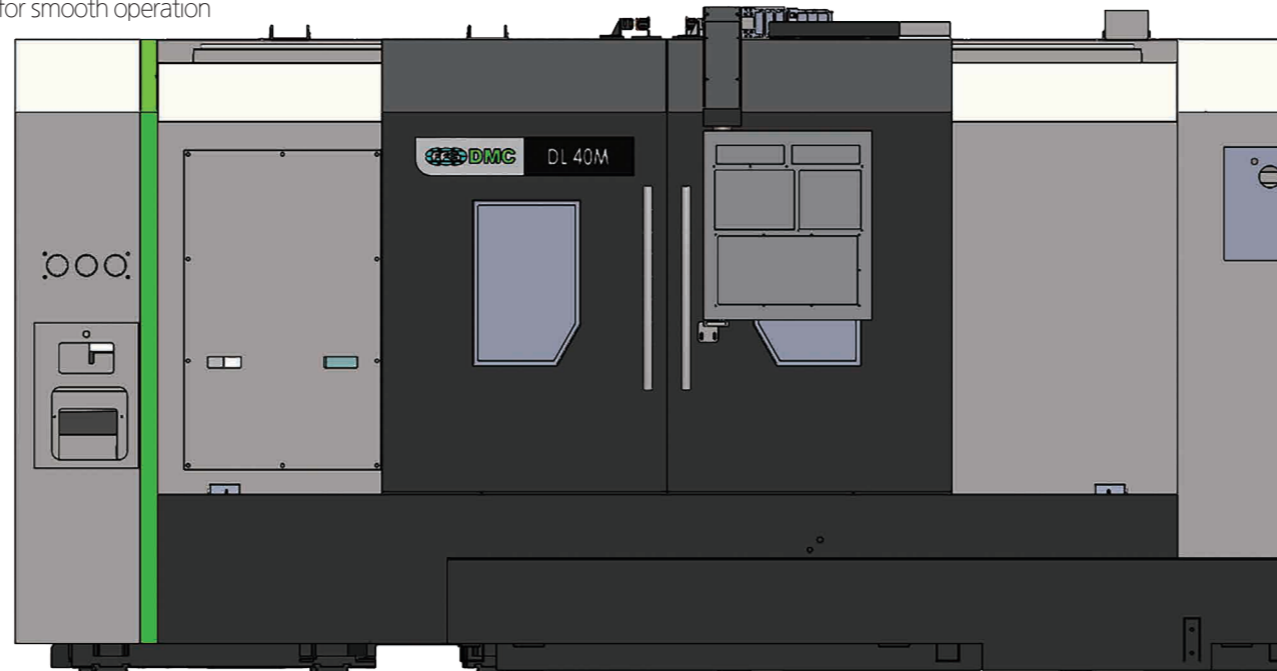

Lubrication unit(3ℓ/0,79gal)



+ Front assembled to be able to confirm by operator

Movable CNC panel



+ Convenient swiveling CNC panel

Coolant gun

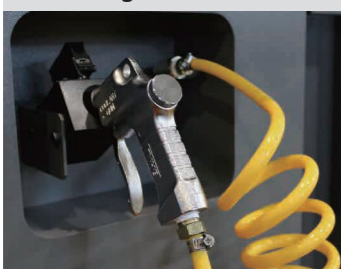

Air gun



Nipple (air, coolant)

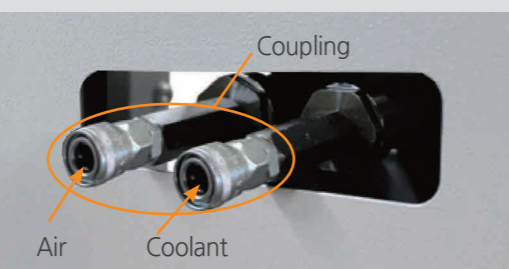

Option

Easy Clean-up Removable Coolant Tank



+ Big size tank
+ Drawer-type oil tank with wheels is detachable from the coolant tank for easy daily maintenance.

Tool setter(OPT.)

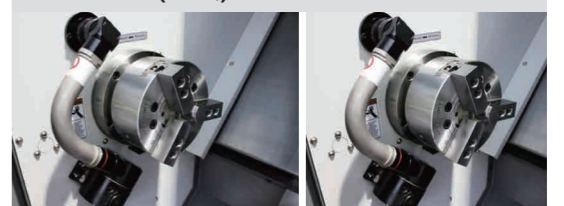

Manual
+ Manual Tool setter
+ Aluminum metallic tube, compact design



Automatic
+ Auto Tool setter
+ Fully authenticated components

Option

Various standard options and Specialized features for customers Features

Standard: Hydraulic chuck, Soft jaw, Tool box, Hydraulic unit, Door interlock, Cutting oil supplying device, Work light, Leveling bolt&place, Foot switch, Air unit, Lubrication unit, 3-step patrol light, Chuck open/close identification, RS232C

Option Equipment

Auto Front Door

Chip conveyor

Moderate/High pressure Coolant(6/20 bar)

Oil Mist Collector

Oil Skimmer(Belt type)

Oil Skimmer(Disk type)

Line Filter(100 Mesh)

Spindle thru Air/Coolant (when special chuck is included)

Part Catcher

Special Chuck

Upper side chuck Air/Coolant

Point Sensor(2 Point high precision position control)

Multi Counter

Sub control panel

Linear scale (High precision position control)

Counter

Air Limit(Workpiece contact surface check equipment)

230ℓ (60.76gal) (Swing)
 300ℓ (79.25gal) (Swing)
 300ℓ (79.25gal) (Fork lift)
 380ℓ (100.38gal) (Fork lift)
 440ℓ (116.23gal) (Fork lift)

Other soft options selection

- I/O extension(16 contacts, 32 contacts)
- Automatic power-off
- M - code

Tooling system

□ : Option(Not-Supplied)

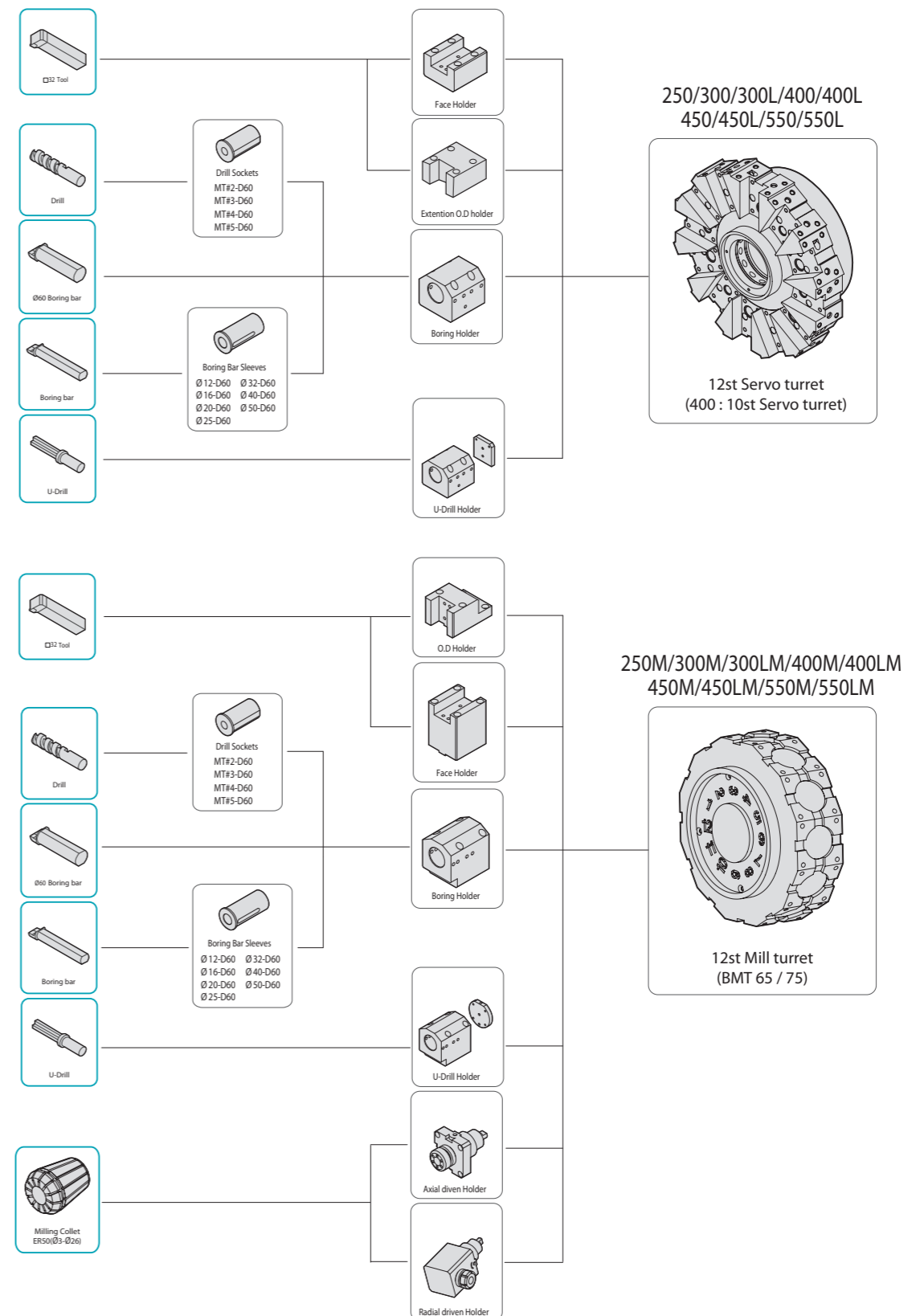

Tooling interference diagram

Unit : mm(inch)

DL 25 / 30 / 30L

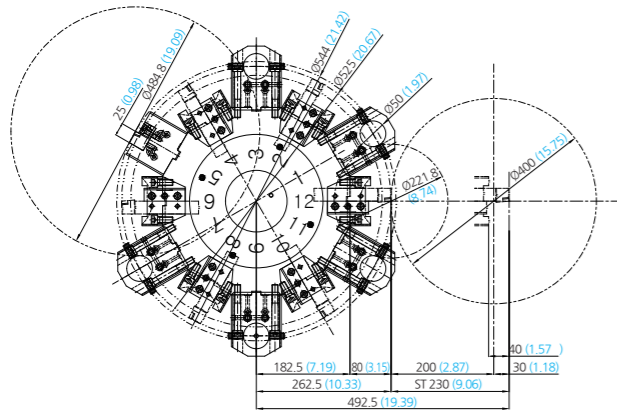

DL 25M / 30M / 30LM

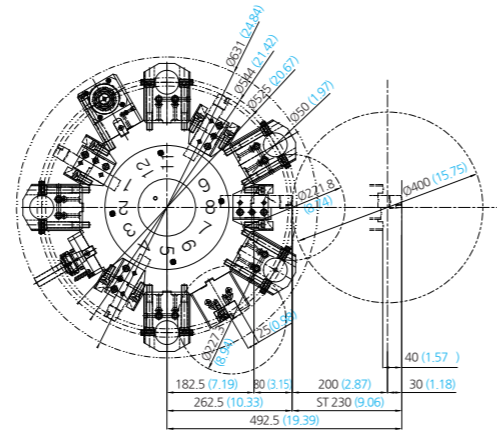

DL40

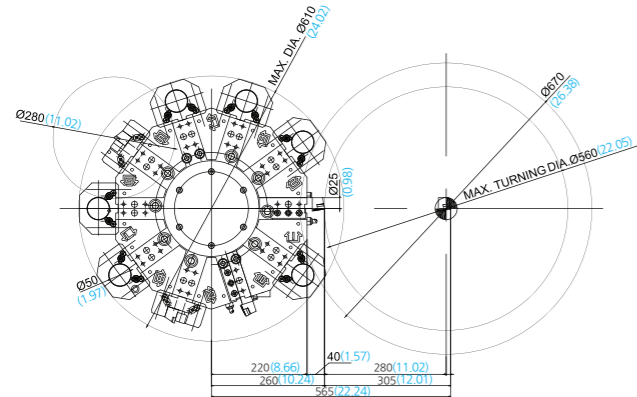

DL 40M

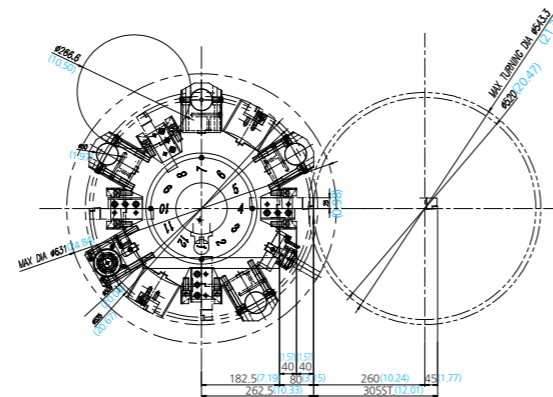

DL 45 / 55

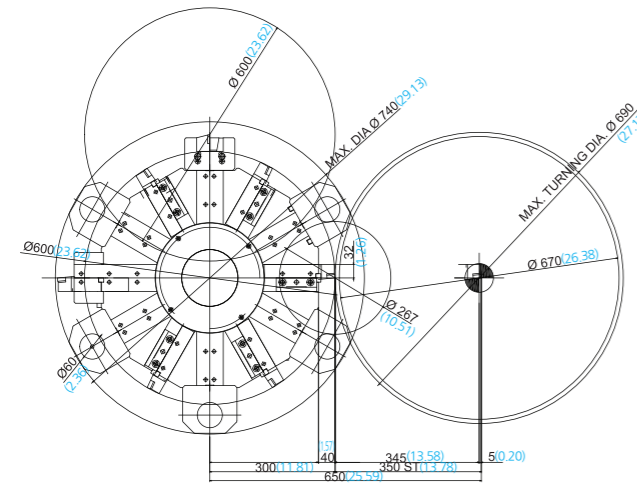

DL 45M / 55M

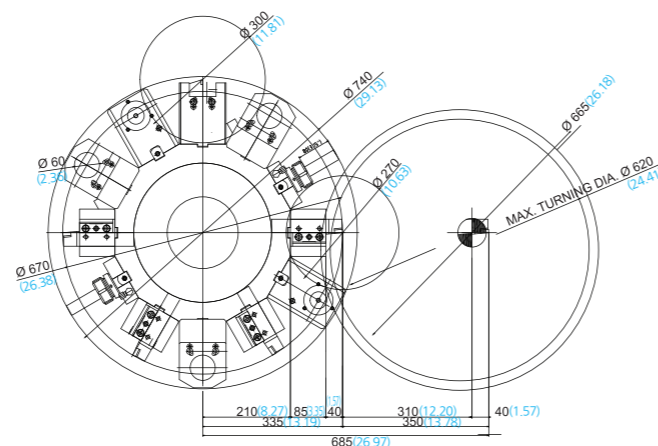

Working range

Unit : mm(inch)

DL 25 / 30(30L)

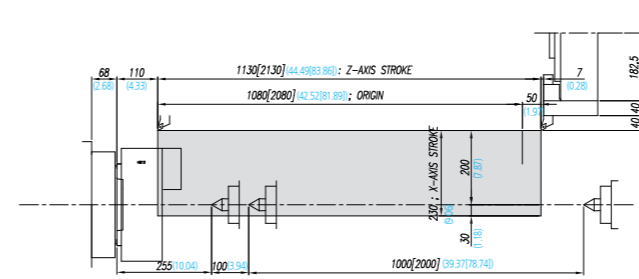

DL 30M(30LM)

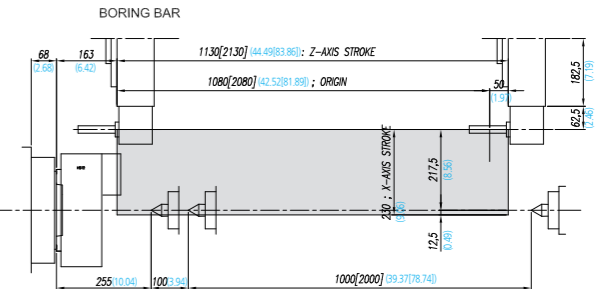

DL 40(40L)

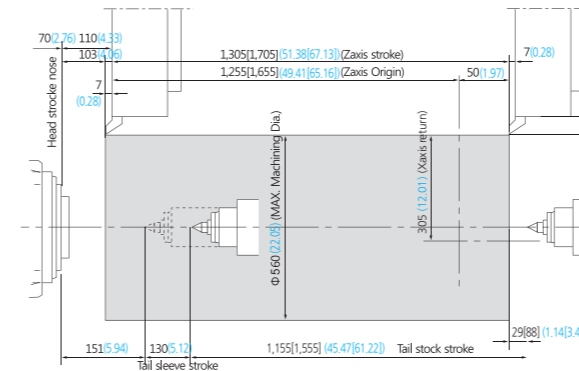

DL 40(L)M

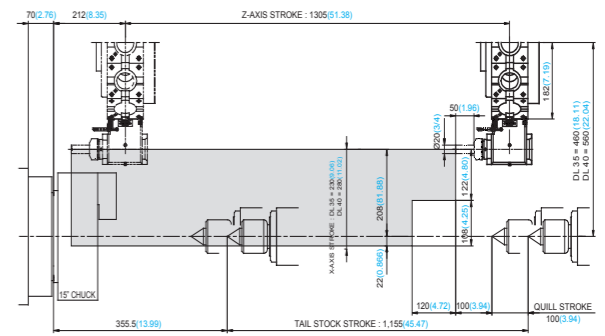

DL 45 / 55(45L / 55L)

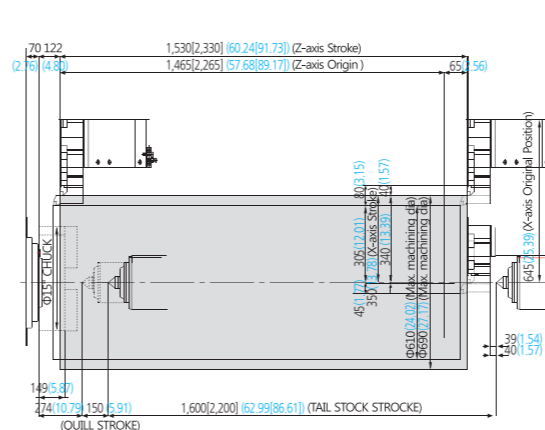

DL 45M / 55M(45LM / 55LM)

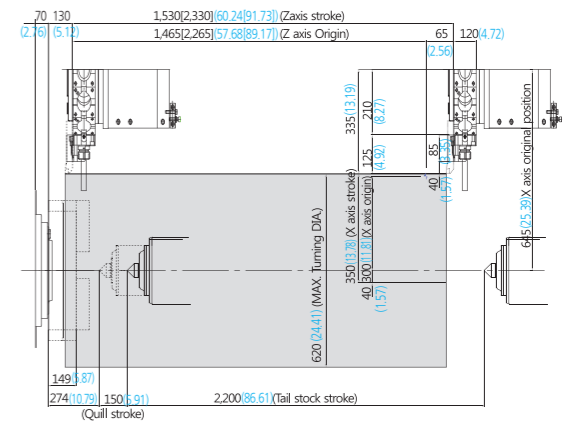

Machine lay-out

Unit : mm(inch)

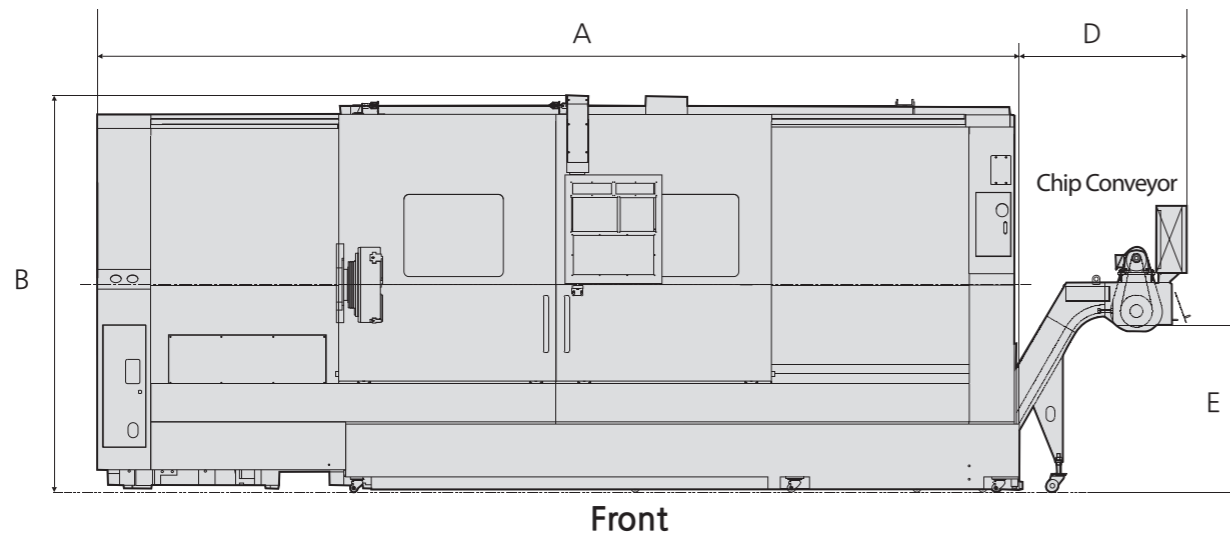

Front

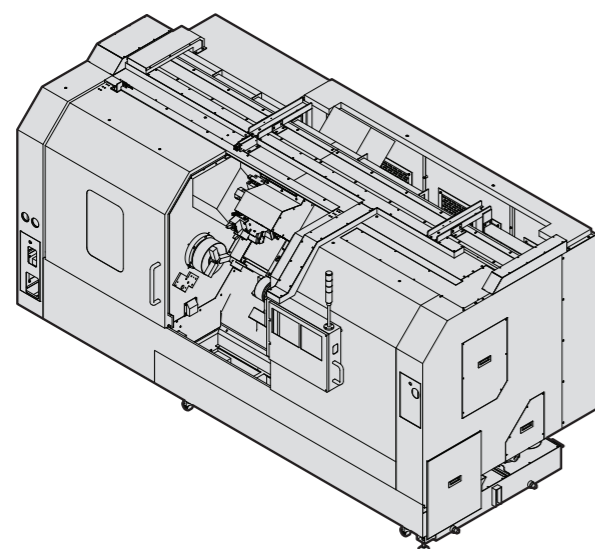

Perspective

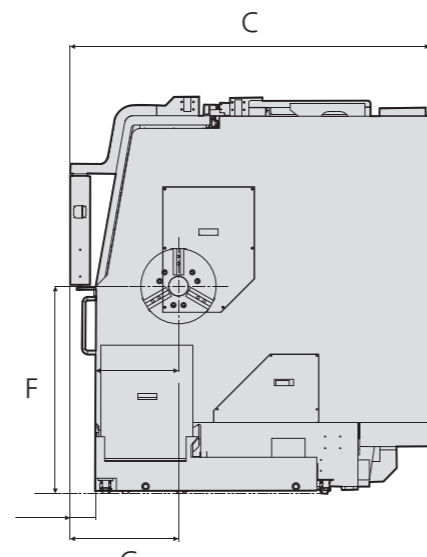

Side

Unit : mm(inch)

Model	A	B	C	D	E	F	G
DL 25/30	3,920(154.33)	2,050(80.71)	1,810(71.26)	968(38.11)	937(36.89)	1,024(40.31)	554(21.81)
DL 30L	5,237(206.18)	2,021(79.57)	1,810(71.26)	913(35.94)	937(36.89)	993(39.09)	505(19.88)
DL 40	4,400(173.23)	2,281(89.8)	1,854(72.99)	968(38.11)	937(36.89)	1,135(44.69)	460(18.11)
DL 40L	5,080(200)	2,292(90.24)	1,876(73.86)	968(38.11)	937(36.89)	1,135(44.69)	460(18.11)
DL 45/55	5,010(197.24)	2,354(92.68)	2,183(85.94)	900(35.43)	1,050(41.34)	1,240(48.82)	614(24.17)
DL 45L/55L	5,810(228.74)	2,354(92.68)	2,183(85.94)	900(35.43)	1,050(41.34)	1,240(48.82)	614(24.17)

Machine Specifications

< > : Option

Specifications	Unit	DL 25	DL 25M	DL 30	DL 30L	DL 30M	DL 30LM		
Capacity	Swing over Bed (Max.swing dia.)	mm (inch)	610(24.02)	610(24.02)	610(24.02)	610(24.02)	610(24.02)		
	Swing over Cross slide	mm (inch)	480(18.90)	480(18.90)	480(18.90)	480(18.90)	480(18.90)		
	Max. Turning Dia.	mm (inch)	400(15.75)	400(15.75)	400(15.75)	400(15.75)	400(15.75)		
	Max. Turning Length	mm (inch)	1,080(42.52)	1,080(42.52)	1,080(42.52)	2,080(81.89)	1,080(42.52)	2,080(81.89)	
Main spindle	Max Spindle Speed	rpm	3,500	3,500	3,000	3,000	3,000		
	Spindle Nose	-	A2-8	A2-8 Mill	A2-8	A2-8	A2-8 Mill		
	Spindle Bore diameter	mm (inch)	86(3.39)	86(3.39)	105(4.13)	105(4.13)	105(4.13)	105(4.13)	
	Max. Spindle Torque	kgf·m (lbs·ft)	39.7(287)	39.7(287)	47.9(346)	47.9(346)	47.9(346)	47.9(346)	
	Chuck Size	inch	10<12>	10<12>	12	12	12	12	
Motor	Main Spindle Motor (Cont./30min)	kw (hp)	15/18.5 (20/25)	15/18.5 (20/25)	15/18.5 (20/25)	15/18.5 (20/25)	15/18.5 (20/25)		
	X axis Servo Motor	kw (hp)	3(4)	3(4)	3(4)	3(4)	3(4)		
	Z axis Servo Motor	kw (hp)	3(4)	3(4)	3(4)	3(4)	3(4)		
Travel	Mill Spindle Motor (Cont./30min)	kw (hp)	-	3.7/5.5 (4.9/7.3)	-	-	3.7/5.5 (4.9/7.3)		
	X axis travel	mm (inch)	230(9.06)	230(9.06)	230(9.06)	230(9.06)	230(9.06)		
	Z axis travel	mm (inch)	1,130(44)	1,130(44)	1,130(44)	2,130(84)	1,130(44)	2,130(84)	
	Guideway Type(X/Z)	-	BOX Way	BOX Way	BOX Way	BOX Way	BOX Way		
	X axis rapid traverse rate	m/min (ipm)	20(787.40)	20(787.40)	20(787.40)	20(787.40)	20(787.40)	20(787.40)	
Z axis rapid traverse rate	m/min (ipm)	24(944.88)	24(944.88)	24(944.88)	18(708.66)	24(944.88)	18(708.66)		
Turret	Turret Index Type	-	Servo	Servo	Servo	Servo	Servo		
	Max. No. of Tools	ea	12	12 / BMT 65	12	12	12 / BMT 65		
	Turning tool shank size	mm (inch)	25(1)	25(1)	25(1)	25(1)	25(1)		
	Boring bar diameter	mm (inch)	50(2)	50(2)	50(2)	50(2)	50(2)		
	Turret Indexing Time (1st swivel)	sec	0.2	0.2	0.2	0.2	0.2		
Tailstock	Tailstock Quill diameter	mm (inch)	110(4.33)	110(4.33)	110(4.33)	110(4.33)	110(4.33)		
	Tailstock Quill stroke	mm (inch)	100(3.94)	100(3.94)	100(3.94)	100(3.94)	100(3.94)		
General	Machine Weight	kgf (lbs)	7,100 (15,652.59)	7,100 (15,652.59)	7,100 (15,652.59)	8,600 (18,959.47)	7,100 (15,652.59)	8,600 (18,959.47)	
	Machine height	mm (inch)	2,050(80.71)	2,050(80.71)	2,050(80.71)	2,021(79.57)	2,050(80.71)	2,021(79.57)	
	Floor space	Length	mm (inch)	3,920 (154.33)	3,920 (154.33)	3,920 (154.33)	5,237 (206.18)	3,920 (154.33)	5,237 (206.18)
		Width	mm (inch)	1,810(71.26)	1,810(71.26)	1,810(71.26)	1,810(71.26)	1,810(71.26)	1,810(71.26)
	Power capacity	kVA	32	34	32	32	32	34	
Controller	-	FOi- TF	FOi- TF	FOi- TF	FOi- TF	FOi- TF	FOi- TF		

Machine Specifications

< >:Option

Specifications		Unit	DL 40	DL 40L	DL 40M	40LM	
Capacity	Swing over Bed (Max.swing dia.)	mm (inch)	750(29.53)	750(29.53)	750(29.53)	750(29.53)	
	Swing over Cross slide	mm (inch)	525(20.67)	525(20.67)	525(20.67)	525(20.67)	
	Max. Turning Dia.	mm (inch)	560(22.05)	560(22.05)	520(20.47)	520(20.47)	
	Max. Turning Length	mm (inch)	1,255(49.41)	1,655(65)	1,255(49.41)	1,655(65)	
Main spindle	Max. Spindle Speed	rpm	2,500	2,500	2,500	2,500	
	Spindle Nose	-	A2-11	A2-11	A2-11 Mill	A2-11 Mill	
	Spindle Bore diameter	mm (inch)	132<161>(5.2<6.34>)	132<161>(5.2<6.34>)	132<161>(5.2<6.34>)	132<161>(5.2<6.34>)	
	Max. Spindle Torque	kgf·m (lbs·ft)	96.3(697)	118<ZF:253>(853<ZF:1830>)	118<ZF:253>(853<ZF:1830>)	96.3(697)	
	Chuck Size	inch	15<18>	15<18>	15<18>	15<18>	
Motor	Main Spindle Motor (Cont./30min)	kw (hp)	18.5/22(25/30)	18.5/22(25/30)	18.5/22(25/30)	18.5/22(25/30)	
	X axis Servo Motor	kw (hp)	4(5.36)	4(5.36)	3(4)	3(4)	
	Z axis Servo Motor	kw (hp)	3(4)	3(4)	3(4)	3(4)	
	Mill Spindle Motor (Cont./30min)	kw (hp)	-	-	3.7/5.5(5/7.4)	3.7/5.5(5/7.4)	
Travel	X axis travel	mm (inch)	305(12.01)	305(12.01)	305(12.01)	305(12.01)	
	Z axis travel	mm (inch)	1,305(51.38)	1,705(67.13)	1,305(51.38)	1,705(67.13)	
	Guideway Type(X/Z)	-	BOX Way	BOX Way	BOX Way	BOX Way	
	X axis rapid traverse rate	m/min (ipm)	18(708.66)	18(708.66)	18(708.66)	18(708.66)	
	Z axis rapid traverse rate	m/min (ipm)	20(787.40)	20(787.40)	20(787.40)	20(787.40)	
Turret	Turret Index Type	-	Servo	Servo	Servo	Servo	
	Max. No. of Tools	ea	10	10	12 / BMT 65	12 / BMT 65	
	Turning tool shank size	mm (inch)	25(1)	25(1)	25(1)	25(1)	
	Boring bar diameter	mm (inch)	50(2)	50(2)	50(2)	50(2)	
	Turret Indexing Time (1st swivel)	sec	0.2	0.2	0.18	0.18	
Tailstock	Tailstock Quill diameter	mm (inch)	130(5.12)	130(5.12)	130(5.12)	130(5.12)	
	Tailstock Quill stroke	mm (inch)	120(4.72)	120(4.72)	120(4.72)	120(4.72)	
General	Machine Weight	kgf (lbs)	8,600(18,959.47)	9,100(20,062)	8,600(18,959.47)	9,100(20,062)	
	Machine height	mm (inch)	2,281(89.80)	2,292(90.24)	2,281(89.80)	2,292(90.24)	
	Floor space	Length	mm (inch)	4,400(173.23)	5,080(200)	4,400(173.23)	5,080(200)
		Width	mm (inch)	1,854(72.99)	1,876(73.86)	1,854(72.99)	1,876(73.86)
	Power capacity	kVA	37	37	42	42	
	Controller	-	F0i- TF	F0i- TF	F0i- TF	F0i- TF	

Machine Specifications

< >:Option

Specifications		Unit	DL 45	DL 45L	DL 45M	DL 45LM	
Capacity	Swing over Bed (Max.swing dia.)	mm (inch)	775(30.51)	775(30.51)	775(30.51)	775(30.51)	
	Swing over Cross slide	mm (inch)	630(24.80)	630(24.80)	630(24.80)	630(24.80)	
	Max. Turning Dia.	mm (inch)	690(27.17)	690(27.17)	620(24.41)	620(24.41)	
	Max. Turning Length	mm (inch)	1,465(57.68)	2,265(89.17)	1,465(57.68)	2,265(89.17)	
Main spindle	Max. Spindle Speed	rpm	2,000	2,000	2,000	2,000	
	Spindle Nose	-	A2-11	A2-11	A2-11 Mill	A2-11 Mill	
	Spindle Bore diameter	mm (inch)	132<161>(5.2<6.34>)	132<161>(5.2<6.34>)	132<161>(5.2<6.34>)	132<161>(5.2<6.34>)	
	Max. Spindle Torque	kgf·m (lbs·ft)	300.4(2,173)	300.4(2,173)	300.4(2,173)	300.4(2,173)	
	Chuck Size	inch	18<21>	18<21>	18<21>	18<21>	
Motor	Main Spindle Motor (Cont./30min)	kw (hp)	30/37(40/50)	30/37(40/50)	30/37(40/50)	30/37(40/50)	
	X axis Servo Motor	kw (hp)	7(9.38)	7(9.38)	7(9.38)	7(9.38)	
	Z axis Servo Motor	kw (hp)	6(8.04)	6(8.04)	6(8.04)	6(8.04)	
	Mill Spindle Motor (Cont./30min)	kw (hp)	-	-	5.5/7.5(7.4/10)	5.5/7.5(7.4/10)	
Travel	X axis travel	mm (inch)	350(13.78)	350(13.78)	350(13.78)	350(13.78)	
	Z axis travel	mm (inch)	1,530(60.24)	2,330(91.73)	1,530(60.24)	2,330(91.73)	
	Guideway Type(X/Z)	-	BOX Way	BOX Way	BOX Way	BOX Way	
	X axis rapid traverse rate	m/min (ipm)	20(787.40)	20(787.40)	20(787.40)	20(787.40)	
	Z axis rapid traverse rate	m/min (ipm)	18(708.66)	18(708.66)	18(708.66)	18(708.66)	
Turret	Turret Index Type	-	Servo	Servo	Servo	Servo	
	Max. No. of Tools	ea	12	12	12 / BMT 75	12 / BMT 75	
	Turning tool shank size	mm (inch)	32(1.26)	32(1.26)	32(1.26)	32(1.26)	
	Boring bar diameter	mm (inch)	60(2.36)	60(2.36)	60(2.36)	60(2.36)	
	Turret Indexing Time (1st swivel)	sec	0.25	0.25	0.25	0.25	
Tailstock	Tailstock Quill diameter	mm (inch)	160(6.30)	160(6.30)	160(6.30)	160(6.30)	
	Tailstock Quill stroke	mm (inch)	150(5.91)	150(5.91)	150(5.91)	150(5.91)	
General	Machine Weight	kgf (lbs)	9,200(20,282.23)	13,200(29,100.59)	9,200(20,282.23)	13,200(29,100.59)	
	Machine height	mm (inch)	2,354(92.68)	2,354(92.68)	2,354(92.68)	2,354(92.68)	
	Floor space	Length	mm (inch)	5,010(197.24)	5,810(228.74)	5,010(197.24)	5,810(228.74)
		Width	mm (inch)	2,202(86.69)	2,183(85.94)	2,202(86.69)	2,183(85.94)
	Power capacity	kVA	59	59	66	66	
	Controller	-	F0i- TF	F0i- TF	F0i- TF	F0i- TF	

Machine Specifications

Specifications		Unit	DL 55	DL 55L	DL 55M	DL 55LM	
Capacity	Swing over Bed (Max.swing dia.)	mm (inch)	775(30.51)	775(30.51)	775(30.51)	775(30.51)	
	Swing over Cross slide	mm (inch)	630(24.80)	630(24.80)	630(24.80)	630(24.80)	
	Max. Turning Dia.	mm (inch)	690(27.17)	690(27.17)	620(24.41)	620(24.41)	
	Max. Turning Length	mm (inch)	1,465(57.68)	2,265(89.17)	1,465(57.68)	2,265(89.17)	
Main spindle	Max. Spindle Speed	rpm	1,700	1,700	1,700	1,700	
	Spindle Nose	-	A2-15	A2-15	A2-15 Mill	A2-15 Mill	
	Spindle Bore diameter	mm (inch)	181(7.13)	181(7.13)	181(7.13)	181(7.13)	
	Max. Spindle Torque	kgf·m (lbs·ft)	300.4(2,173)	300.4(2,173)	300.4(2,173)	300.4(2,173)	
	Chuck Size	inch	21	21	21	21	
Motor	Main Spindle Motor (Cont./30min)	kw (hp)	30/37(40/50)	30/37(40/50)	30/37(40/50)	30/37(40/50)	
	X axis Servo Motor	kw (hp)	7(9.38)	7(9.38)	7(9.38)	7(9.38)	
	Z axis Servo Motor	kw (hp)	6(8.04)	6(8.04)	6(8.04)	6(8.04)	
	Mill Spindle Motor (Cont./30min)	kw (hp)	-	-	5.5/7.5(7.4/10)	5.5/7.5(7.4/10)	
Travel	X axis travel	mm (inch)	350(13.78)	350(13.78)	350(13.78)	350(13.78)	
	Z axis travel	mm (inch)	1,530(60.24)	2,330(91.73)	1,530(60.24)	2,330(91.73)	
	Guideway Type(X/Z)	-	BOX Way	BOX Way	BOX Way	BOX Way	
	X axis rapid traverse rate	m/min (ipm)	20(787.40)	20(787.40)	20(787.40)	20(787.40)	
	Z axis rapid traverse rate	m/min (ipm)	18(708.66)	18(708.66)	18(708.66)	18(708.66)	
Turret	Turret Index Type	-	Servo	Servo	Servo	Servo	
	Max. No. of Tools	ea	12	12	12 / BMT 75	12 / BMT 75	
	Turning tool shank size	mm (inch)	32(1.26)	32(1.26)	32(1.26)	32(1.26)	
	Boring bar diameter	mm (inch)	60(2.36)	60(2.36)	60(2.36)	60(2.36)	
	Turret Indexing Time (1st swivel)	sec	0.25	0.25	0.25	0.25	
Tailstock	Tailstock Quill diameter	mm (inch)	160(6.30)	160(6.30)	160(6.30)	160(6.30)	
	Tailstock Quill stroke	mm (inch)	150(5.91)	150(5.91)	150(5.91)	150(5.91)	
General	Machine Weight	kgf (lbs)	9,200(20,282.23)	13,200(29,100.59)	9,200(20,282.23)	13,200(29,100.59)	
	Machine height	mm (inch)	2,354(92.68)	2,354(92.68)	2,354(92.68)	2,354(92.68)	
	Floor space	Length	mm (inch)	5,010(197.24)	5,810(228.74)	5,010(197.24)	5,810(228.74)
		Width	mm (inch)	2,202(86.69)	2,183(85.94)	2,202(86.69)	2,183(85.94)
	Power capacity	kVA	59	59	66	66	
Controller	-	F0i-TF	F0i-TF	F0i-TF	F0i-TF		

NC Specifications (FANUC FOi-TF)

○ : Standard, OPT. : Option, (!) : M type, (!!): 2SO type

	Item	Specification	0iTF	
Controls	Controlled axes	Std. 2axes	X, Z, C (!)	
	Simultaneously control axes expansion(Total)	0.001mm/0.0001"	3 axes (!)	
Axis Functions	Least input increment		○	
	Cs contouring control		○ (!)	
	HRV2 Control		○	
	Inch/metric conversion	G20/G21	○	
	Increment system 1/10	0.0001mm/0.00001"	○	
	Stored stroke 1	Overtravel control	○	
	Stored stroke 2 and 3		○	
	Mirror image		○	
	Chamfering on/off		○	
	Backlash compensation	Max. 255 pulses	○	
Operation	Stored pitch error compensation		○	
	Automatic operation(memory)		○	
	MDI operation		○	
	Buffer register		○	
	Program restart		○	
	Search function	Sequence NO. / Program NO. / Address	○	
	DNC operation		○	
	Reference position shift		-	
	Manual handle feed rate	X1, X10, X100	○	
	Manual pulse generator	1 unit	○	
Interpolation	Manual handle interruption		○	
	Linear interpolation	G01	○	
	Circular interpolation	G02, G03	○	
	Dwell	G04	○	
	Polar coordination interpolation	G12.1, G13.1	○ (!)	
	Cylindrical interpolation		○ (!)	
	Thread cutting/Synchronous cutting		○	
	Multiple threading		○	
	Thread cutting retract		○	
	1st, 2nd reference position return & check	G27, G28, G30	○	
Feed functions	Variable lead thread cutting		○	
	Continuous thread cutting		○	
	Circular thread cutting		OPT.	
	3rd and 4th reference point return		○	
	polygon turning		OPT.	
	Helical interpolation		OPT.	
	Rapid traverse override	F0/25/50/100%	○	
	Feedrate Override	0-200% (10% unit)	○	
	Jog feed override	0-2000 mm/min	○	
	Feed per minute	G98	○	
Axullary & Spindle functions	Feed per revolution	G99	○	
	Cutting feedrate clamp		○	
	External deceleration		○	
	Feed stop		-	
	AI Comtour contr II of I/II		OPT.	
	Spindle speed override	0~150%	○	
	Constant surface speed control	G96, G97	○	
	1st Spindle orientation		○	
	Rigid tapping		○	
	Multi-spindle control		○ (!)	
Programming functions	Auxiliary function	M8 digit	○	
	Program/code	EIA/ISO	○	
	Optional block skip	1 Piece	○	
	Additional block skip	Total 9(Only NC function)	○	
	Tool functions	Maximum command dimension	± 99999.999mm(± 9999.9999 inch)	○
		Program file name	32 characters	○
		Sequence number	N8 digit	○
		Absolute / Incremental programming		○
		Decimal point input		○
		Work coordinate system selection	G52 ~ G59	○
Direct drawing dimension programming			○	
G code system A/B/C			○	
G code system B/C(selectable)			○	
Chamfering / corner R			○	
Editing op. functions	Programmable data input	G10	○	
	Sub program call	Nested holds	10	
	Custom macro		○	
	Simple canned cycles	G90, G92, G94	○	
	Circular interpolation by R programming		○	
	Multi repetitive canned cycle	G70 ~ G76	○	
	Multi repetitive canned cycle2		○	
	Drilling canned cycle(G80 series)		○	
	Tape format for FANUC series 10/11		○	
	Manual guide oi		OPT.	
Setting & display	Tool number command(t-code function)	T4-digit	○	
	Number of tool offsets		128 Pairs	
	Tool offset	G43, G44, G49	○	
	Tool nose radius compensation	G40 ~ G42	○	
	Tool geometry / wear offset	Geometry & wear data	○	
	Tool life management		○	
	Tool offset value counter input		○	
	Auto tool offset		○	
	Direct input of tool offset value measured B		○	
	Part program storage size		512 kb	
No. of Registered programs		400 ea		
Data input & output	Part program editing		○	
	Program protect		○	
	Background editing		○	
	Expanded part program editing	Copy, Move, Change of NC program	○	
	Status display		○	
	Program name display	31 characters	○	
	Self diagnostic function		○	
	Help function	Alarm & Operations display	○	
	Running time / Parts number display	Auto running time & Parts No. display	○	
	Load meter display	Spindle & Servo load display	○	
Other functions	External message display		○	
	Display of spindle speed and T-code at all screen		○	
	Tool path graphic display		○	
	Servo setting screen		○	
	Spindle setting screen		○	
	Multi language display		○	
	I/O interface	RS-232C/LAN Port	○	
	Memory card input and output		○	
	External key input		○	
	External program input		○	
External work number search		○		
USB Memory	Input/Output	○		
Fast Data Server	Only 1 path, need option board	OPT		
MDI / DISPLAY unit		10.4"		
PMC system		○		
Ethernet function	Embedded ethernet function	○		